

REV.	DATE	DESCRIPTION
A	06/05/03	UPDATE DRAWING FORMAT

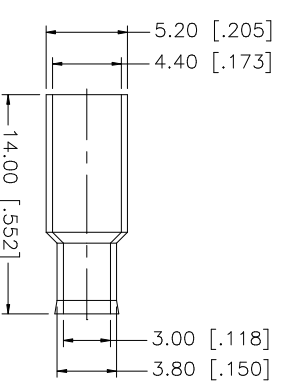
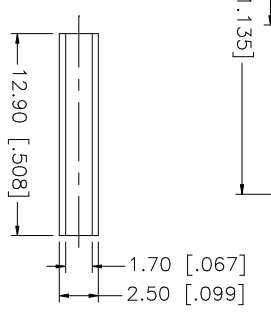
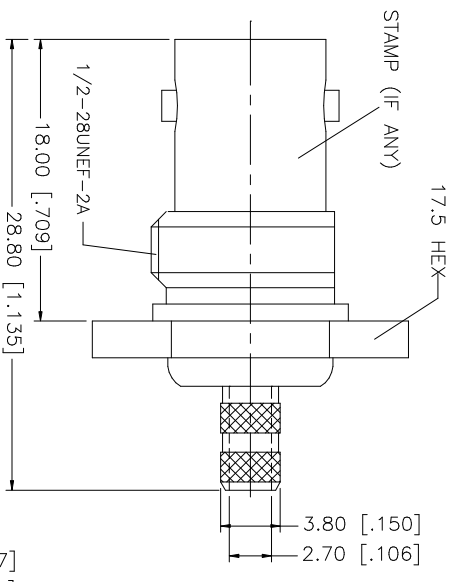
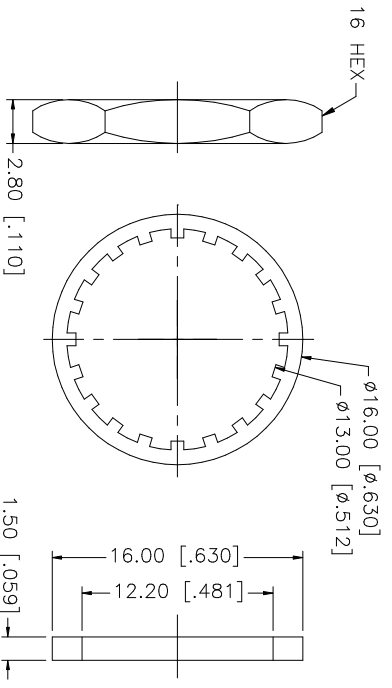
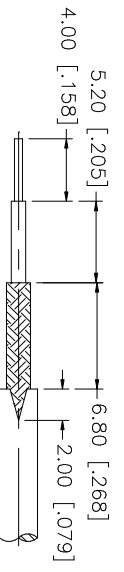

CRIMP NOTES:

1. CRIMPED FERRULE HEX CRIMP SIZE .178"
2. CRIMPED CONTACT PIN HEX CRIMP SIZE .068"
3. MAX. PANEL THICKNESS = 3.5mm

RECOMMENDED MOUNTING HOLE

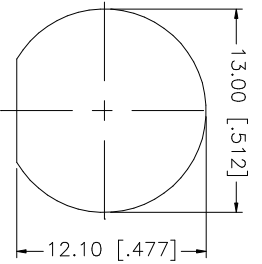

DESCRIPTION	MATERIAL	FINISH	QTY	DO NOT SCALE DRAWING	CAD FILE	DWG. NO.	REV.	SIZE	SCALE
9 FERRULE	BRASS	NICKEL	1	UNLESS OTHERWISE SPECIFIED DIMENSIONS ARE IN MILLIMETERS, DIMENSIONS IN [] ARE IN INCHES AND FOR CUSTOMER REFERENCE ONLY.	APPROVALS	DATE			
8 SLEEVE	DELRIN	NATURAL	1	UNLESS OTHERWISE SPECIFIED TOLERANCES FOR MILLIMETERS ARE:	DRAWN G.R.S.	06/05/03			
7 CONTACT PIN	PHOS. BRONZE	GOLD	1	0.5 - 8mm ± 0.20mm	CHECKED				
6 HEX NUT	BRASS	NICKEL	1	8 - 30mm ± 0.40mm	ISSUED				
4 LOCK WASHER	BRASS	NICKEL	1	30 - 120mm ± 0.50mm	SHEET	1 OF 1			
3 GASKET	RUBBER	NICKEL	1	UNLESS OTHERWISE SPECIFIED TOLERANCES FOR INCHES ARE:	PART NO.				
2 INSULATOR	DELRIN	NATURAL	1	.020 - .315 = ± 0.007"					
1 BODY	BRASS	NICKEL	1	.315 - 1.180 = ± 0.015"					
1				1.180 - 4.724 = ± 0.020"					

Amphenol **Comnex**

BNC BULKHEAD CRIMP JACK
(FOR RG-174/U, 188A/U, 316/U CABLE)

112234